



3 Reach-In Glass Door Freezer (Swing Door) ♦ NPGF3-SB



NPGF3-S ▶

Standard Feature

- ♦ Bottom Mounted Compressor
- ♦ Functional Accessory / Control Shelves
- ♦ Removable Door Gasket
- ♦ Insulating Anti-Fog Glass Door
- ♦ Accurate Temperature Control
- ♦ Interior LED lighting
- ♦ Heavy-duty caster wheels

Technical Specifications

Product Classification	Freezer
Climate Class	N
Power	2358W
Number of Doors / Lids	3
External Cabinet Material	Coated Steel
Internal Cabinet Material	Aluminum Liner with Steel Floor
Type of Refrigeration Agent	R-404A
Type of Temperature Control	Digital
Temperature Range °C	-23°C to -18°C
Temperature Range °F	-10°F to 0°F
Voltage / Frequency	115V / 60Hz
Amp	20.5
Compressor HP	(2) 3/4+ HP
Type of Insulation	3.0-Inch Polyurethane Foam
Door Handle	Partial

Certified Safety Standard

- ♦ ETL Listed
- ♦ ETL Sanitation Listed



Warranty Information

- ♦ 5 Years Compressor
- ♦ 3 Year Parts & Labor





3 Reach-In Glass Door Freezer (Swing Door) ♦ NPGF3-SB

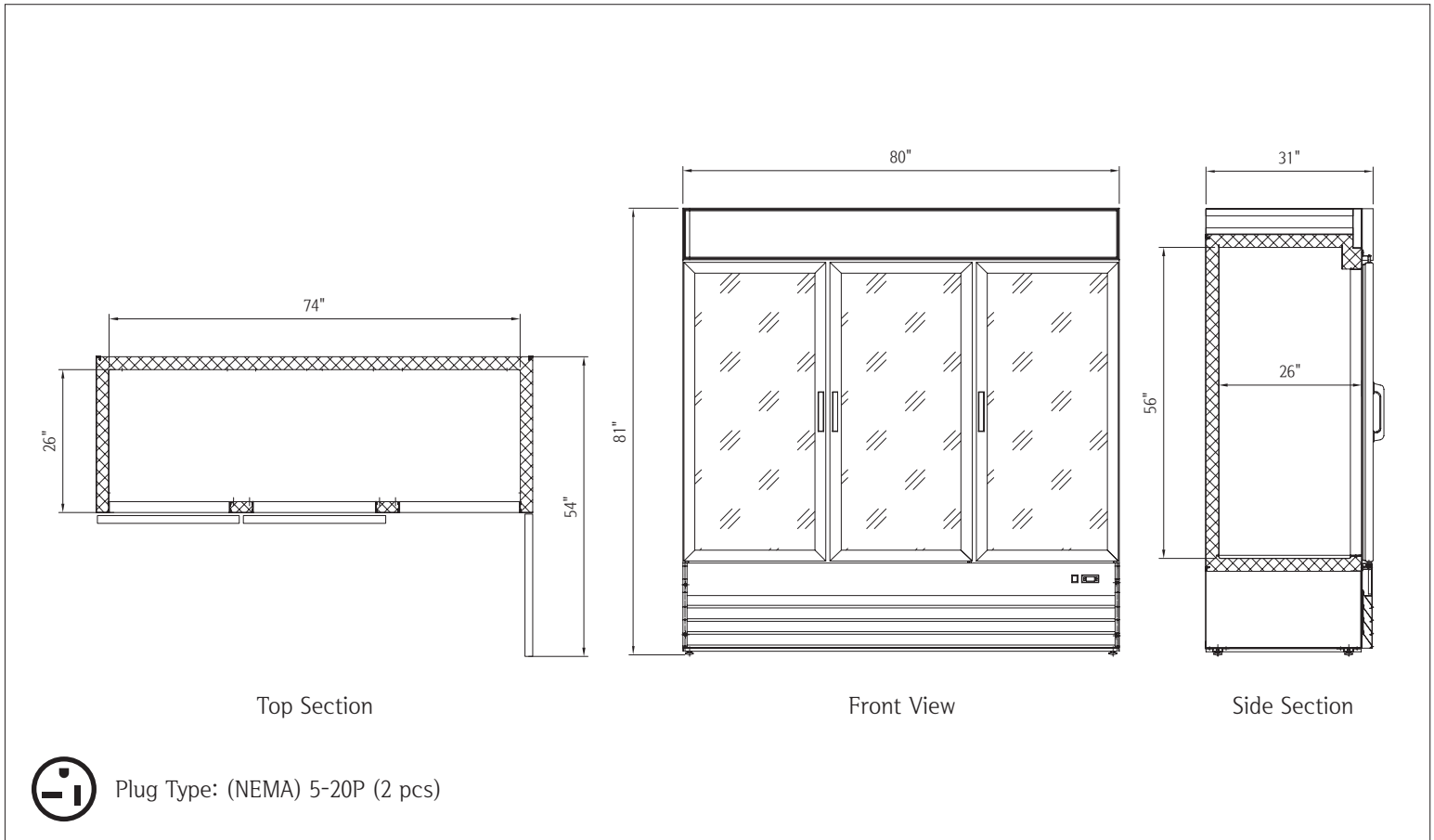

Capacity

Capacity 52 cu. ft.

Dimensions

Internal Cabinet Width 74 in

Internal Cabinet Depth 26 in

Internal Cabinet Height 56 in

External Width 80 in

External Depth 31 in

External Height 81 in

Shipping Dimensions (W x D x H) 83 x 33 x 85 in

Weight

Gross Weight 870 lbs.

Accessories

Cycle Defrosting Yes

Frost Free Yes

Adjustable Shelves 12

Fixed Shelves No

Internal Light Yes

Internal Light Switch No

External Light Switch No

Self Closing Door/Lid Yes

Adjustable Thermostat Yes