

norpole

1 Reach-In Glass Door Freezer (Swing Door) ♦ NPGF1-SB



Standard Feature

- ♦ Bottom Mounted Compressor
- ♦ Functional Accessory / Control Shelves
- ♦ Removable Door Gasket
- ♦ Insulating Anti-Fog Glass Door
- ♦ Accurate Temperature Control
- ♦ Interior LED lighting
- ♦ Heavy-duty caster wheels

Technical Specifications

Product Classification	Freezer
Climate Class	N
Number of Doors / Lids	1
External Cabinet Material	Coated Steel
Internal Cabinet Material	Aluminum Liner with Steel Floor
Type of Refrigeration Agent	R-290
Type of Temperature Control	Digital
Temperature Range °C	-23°C to -18°C
Temperature Range °F	-10°F to 0°F
Voltage / Frequency	115V / 60Hz
Amp	9.4
Compressor HP	3/4
Type of Insulation	3.0-Inch Polyurethane Foam
Door Handle	Partial

Certified Safety Standard

- ♦ ETL Listed
- ♦ ETL Sanitation Listed



Warranty Information

- ♦ 5 Years Compressor
- ♦ 3 Year Parts & Labor





1 Reach-In Glass Door Freezer (Swing Door) ♦ NPGF1-SB

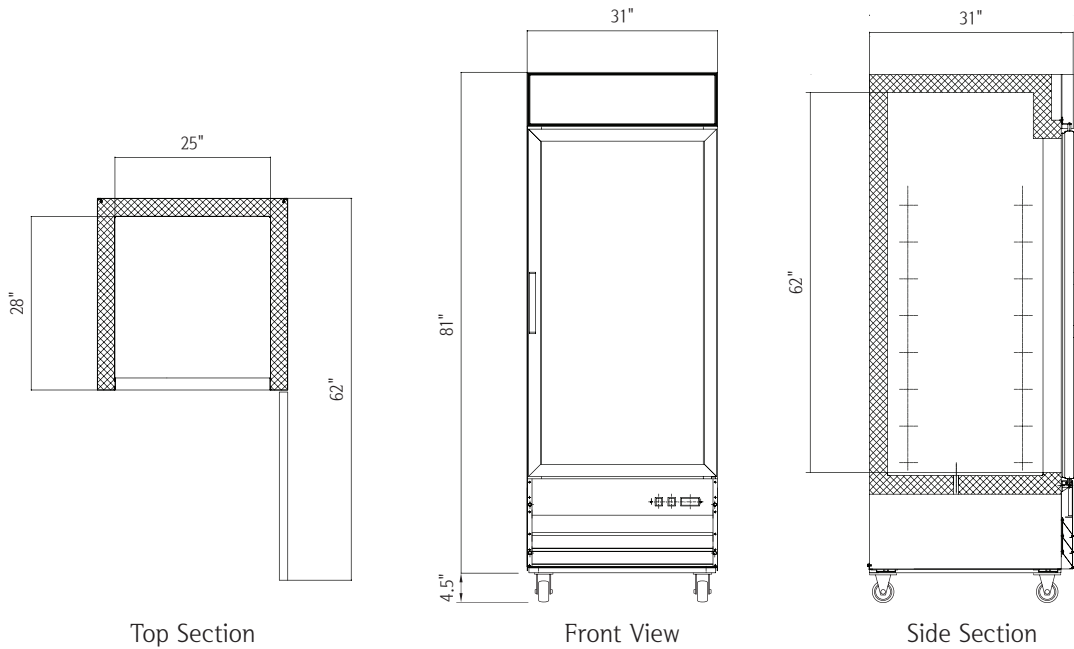

Plug Type: (NEMA) 5-15P

Capacity

Capacity 23 cu. ft.

Dimensions

Internal Cabinet Width	25 in
Internal Cabinet Depth	28 in
Internal Cabinet Height	62 in
External Width	31 in
External Depth	31 in
External Height	85.5 in
Shipping Dimensions (W x D x H)	33 x 37 x 89 in

Weight

Gross Weight 551 lbs.

Accessories

Cycle Defrosting	Yes
Frost Free	Yes
Adjustable Shelves	4
Fixed Shelves	No
Internal Light	Yes
Internal Light Switch	No
External Light Switch	No
Self Closing Door/Lid	Yes
Adjustable Thermostat	Yes