

norpole

2 Door Under Counter Freezer ♦ NP2F-48UC



Standard Features

- ♦ Stainless steel interior and exterior
- ♦ Rounded corner design for easy cleanup
- ♦ Self closing hinged doors with 90 degree stay open feature
- ♦ Programmable electronic control system
- ♦ Adjustable, heavy duty PVC coated shelves
- ♦ Heavy-duty castor wheels

Technical Specifications

Product Classification	Freezer
Climate Class	N
Number of Doors	2
External Cabinet Material	430 Stainless Steel
Internal Cabinet Material	304 Stainless Steel
Type of Refrigeration Agent	R-290
Type of Temperature Control	Digital
Temperature Range °C	-22°C to -18°C
Temperature Range °F	-8°F to 0°F
Voltage / Frequency	115V / 60Hz
Amp	4.5
Compressor HP	1/4+
Type of Insulation	2.5-Inch Polyurethane Foam
Door Handle	Full Length

Certified Safety Standard

- ♦ ETL Listed
- ♦ ETL Sanitation Listed



Warranty Information

- ♦ 5 Years Compressor
- ♦ 3 Year Parts & Labor





2 Door Under Counter Freezer ♦ NP2F-48UC

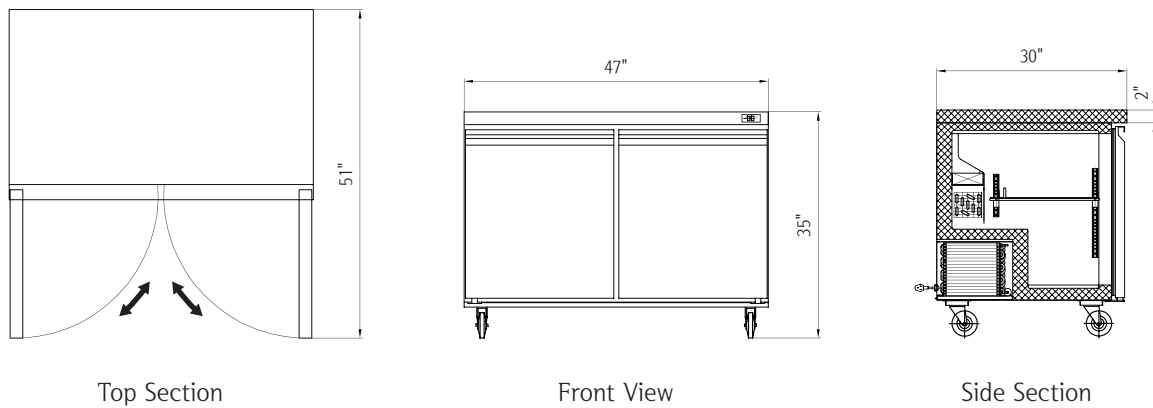

Plug Type: (NEMA) 5-15P

Capacity

Capacity 12 cu. ft.

Dimensions

Internal Cabinet Width	43 in
Internal Cabinet Depth	23 in
Internal Cabinet Height	24 in
External Width	47 in
External Depth	30 in
External Height	35 in
Shipping Dimensions (W x D x H)	50 x 32 x 39 in

Weight

Gross Weight 311 lbs.

Accessories

Cycle Defrosting	Yes
Frost Free	Yes
Adjustable Shelves	2
Fixed Shelves	No
Internal Light	No
Internal Light Switch	No
External Light Switch	No
Self Closing Door / Lid	Yes
Door Holder for Loading	Yes
Door / Lid Lock	No
Reversible (Left) Door	No
Adjustable Feet	Optional
Adjustable Thermostat	Yes